

**Great Lakes Energy**  
***Generator Interconnection Requirements***  
***Projects with***  
***Aggregate Generator Output***  
***of 750 kW or More, but Less than 2 MW***



# INTRODUCTION

This Generator Interconnection Requirements document outlines the process, requirements, and agreements used to install or modify generation projects with aggregate generator output capacity ratings of 750 kW or more, but less than 2 MW, and designed to operate in parallel with the Great Lakes Energy (GLE) electric system. Technical requirements (data, equipment, relaying, telemetry, metering) are defined according to the size and type of generation, location of the interconnection, and mode of operation (Flow-back or Non-Flow-back). The process is designed to provide an expeditious interconnection to the GLE electric system that is both safe and reliable. Interconnection requests desiring to connect to the area's transmission system should be directed to the appropriate transmission provider.

This document has been filed with the Michigan Public Service Commission (MPSC) and complies with rules established for the interconnection of parallel generation to the GLE electric system in the MPSC Order in Case No. U-13745.

The term "Project" will be used throughout this document to refer to a merchant plant and other electric generating equipment and associated facilities that are not owned or operated by an electric utility. The term "Project Developer" means a person that owns, operates, or proposes to construct, own, or operate, a Project. The term "Utility" will be used throughout this document to refer to Great Lakes Energy.

This document does not address other Project concerns such as environmental permitting, local ordinances, or fuel supply. Nor does it address agreements that may be required with GLE and/or the transmission provider, or state or federal licensing, to market the Project's energy. An interconnection request does not constitute a request for transmission service.

It may be possible for GLE to adjust requirements stated herein on a case-by-case basis. The review necessary to support such adjustments, however, may be extensive and interfere with study fees and the project schedule established by the MPSC and addressed in these requirements. Therefore, if requested by the Project Developer, adjustments to these requirements will only be considered if the Project Developer agrees in advance to compensate GLE for the added costs of the necessary additional reviews and to also allow GLE additional time for the additional reviews.

GLE may apply for waiver from one or more provisions of these rules and the MPSC may grant a waiver upon a showing of good cause.



# CONTENTS

<b>THE INTERCONNECTION PROCESS.....</b>	<b>1</b>
<b>Interconnection Application.....</b>	<b>1</b>
<b>Interconnection Study .....</b>	<b>2</b>
<b>Interconnection and Operating Agreement.....</b>	<b>2</b>
<b>Project Design and Construction .....</b>	<b>2</b>
<b>Ongoing Operations .....</b>	<b>2</b>
<b>TECHNICAL REQUIREMENTS.....</b>	<b>3</b>
<b>Major Component Design Requirements.....</b>	<b>3</b>
Data .....	3
Isolating Transformer(s).....	3
Isolation Device.....	3
Interconnection Lines.....	4
Termination Structure .....	4
<b>Relaying Design Requirements .....</b>	<b>4</b>
Protective Relaying General Considerations .....	5
Momentary Paralleling .....	5
Instrument Transformer Requirements.....	5
Direct Transfer Trip (DTT) .....	5
Reverse Power Relaying for Non-Flow-back.....	6
Automatic Reclosing .....	6
Single-Phase Sectionalizing .....	6
Synchronous Projects.....	7
Induction Projects .....	8
Inverter-Type Projects.....	9
Relay Setting Criteria .....	10
Maintenance and Testing .....	11
Installation and Design Approval .....	11
<b>Telemetry and Disturbance Monitoring Requirements .....</b>	<b>12</b>
<b>Miscellaneous Operational Requirements.....</b>	<b>14</b>
Operating in Parallel .....	14
Reactive Power Control .....	15
Standby Power.....	15
System Stability and Site Limitations.....	15
<b>Revenue Metering Requirements .....</b>	<b>16</b>
<b>Communication Circuits.....</b>	<b>17</b>

# CONTENTS

APPENDIX A	INTERCONNECTION APPLICATION
APPENDIX B	SYNCHRONOUS AND INDUCTION GENERATORS - REQUIRED DATA
APPENDIX C	INVERTER-TYPE GENERATORS - REQUIRED DATA
APPENDIX D	INTERCONNECTION STUDY AGREEMENT
APPENDIX E	INTERCONNECTION AND OPERATING AGREEMENT
APPENDIX F	CONTACT LIST

# INTERCONNECTION PROCESS

## The Interconnection Process

This section outlines the process for interconnecting 750 kW or more, but less than 2 MW of generation to the Utility electric system. This includes both new Projects and modifications to existing Projects. The general process is shown in Figure 1.

The Utility is required to complete all of its obligations for interconnection of the Project to the Utility system within 12 weeks from the time a complete Interconnection Application is received by the Utility.

A complete Interconnection Application consists of an application, data (Appendix B or C), and filing fee.

Delays that are the responsibility of Project Developer or attributable to the time lapse while the Utility diligently seeks to secure necessary rights-of-way, governmental permitting, zoning requirements, etc, will not be counted in the time to meet the 12 week deadline. The Utility shall have no responsibility to pursue court action to obtain these items.

### **Interconnection Application**

The Project Developer must first submit an Interconnection Application to the Utility. A separate application is required for each Project or Project site. A blank Interconnection Application can be found in Appendix A. A list of the required interconnection data, depending on the capacity rating and type of generation, can be found in Appendices B and C.

A complete submittal of required interconnection data and filing fee of \$0.50 per kW (but in no event shall the amount of the fee be less than \$100 or more than \$500) must accompany the Interconnection Application. The Utility will notify the Project Developer within 3 business days of receipt of an Interconnection Application. If any portion of the Interconnection Application, data submittal, or filing fee is incomplete and/or missing, the unapproved Interconnection Application will be sent back to the Project Developer with the deficiencies clearly identified.

Once the Utility has accepted an Interconnection Application, the Project is assigned a position in the Project queue maintained by the Utility. The Project position in the Project queue is determined by the date the Utility received the accepted Interconnection Application. The Utility will provide the Project Developer up to two hours of consultation related to the Project's interconnection to the Utility system and will include a

Figure 1: The Interconnection Process

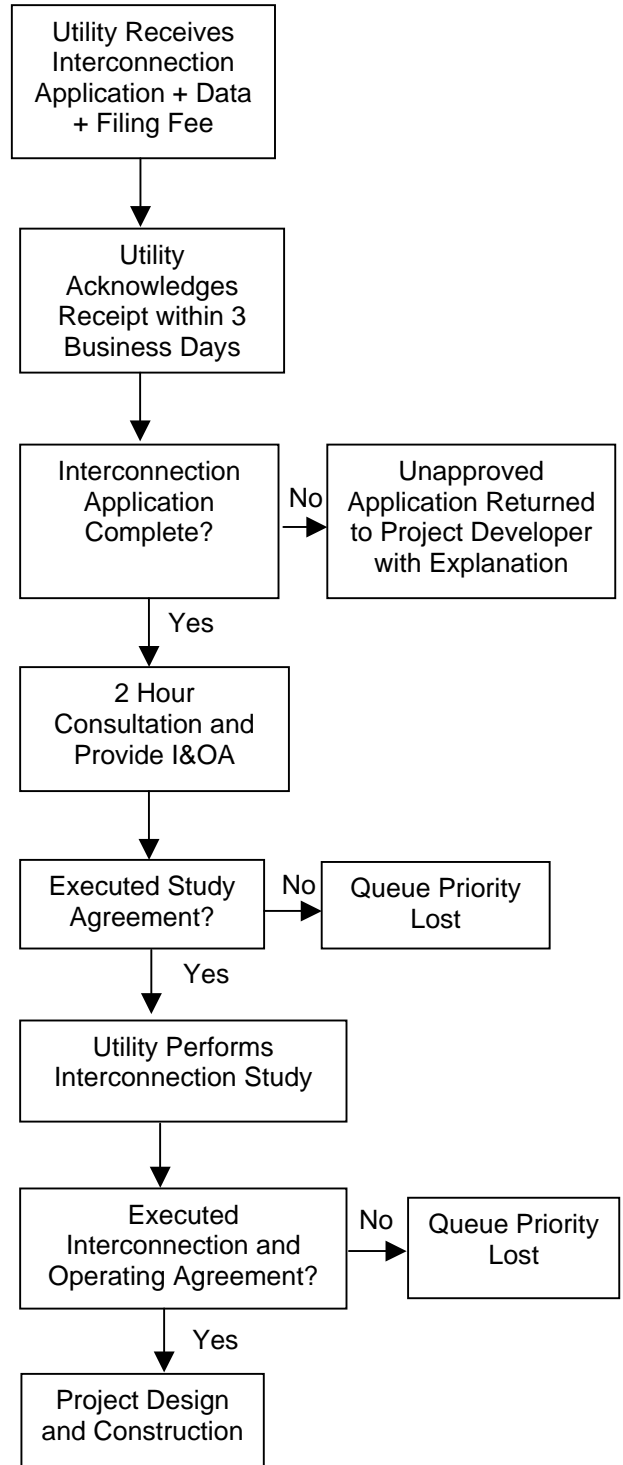

# INTERCONNECTION PROCESS

good faith estimate of the Utility's charges to complete the interconnection, including the estimated study fees, based on the information available to the Utility at that time.

## ***Interconnection Study***

The Utility will perform an Interconnection Study to determine the impact of the project on the Utility's system, and the Utility system modifications required for safe and reliable interconnection of the Project to the Utility's system. The Project Developer is required to sign the Interconnection Study Agreement found in Appendix D and is encouraged to return the signed Interconnection Study Agreement to the Utility with the completed Interconnection Application to avoid delays in the interconnection process. Any delay in execution of the Interconnection Study Agreement will not toll the interconnection deadlines.

The Utility will charge the Project Developer for the costs associated with completion of the Interconnection Study. The costs will not exceed the lesser of either of the following:

- (1) Five percent of the estimated total cost of the Project, or
- (2) \$10,000

Interconnection Study fees are not required if the Interconnection Study determines that the Project's aggregate export capacity is less than 15% of the line section peak load and the project does not contribute more than 25% of the maximum short circuit current at the Point of Common Coupling (PCC) as defined by IEEE 1547.

## ***Interconnection and Operating Agreement***

The Utility will submit an Interconnection and Operating Agreement (I&OA) to the Project Developer, as soon as practical, after the 2 hour consultation described earlier. A sample Interconnection and Operating Agreement can be found in Appendix E.

The Interconnection and Operating Agreement will cover matters customarily addressed in such agreements in accordance with Good Utility Practice, including, without limitation, construction of facilities, system operation, interconnection cost and billing, defaults and remedies, insurance, and liability. All Utility costs associated with making modifications to its distribution system will be paid by the Project Developer.

Any delay in execution of the Interconnection and Operating Agreement will not count toward the interconnection deadlines.

## ***Project Design and Construction***

After the Interconnection and Operating Agreement is executed, the Utility will proceed to acquire necessary rights-of-way, procure required equipment, and design and construct the Interconnection Facilities.

## ***Ongoing Operations***

The Project Developer and Utility will exchange contact information and update this information from time to time. A sample Contact List can be found in Appendix F.

# TECHNICAL REQUIREMENTS

## Technical Requirements

The following discussion details the technical requirements for interconnection of Projects with aggregate generator output of 750 kW or more, but less than 2 MW. Many of these requirements will vary based on the capacity rating of the Project, type of generation being used, and mode of operation (Flow-back or Non-Flow-back). A few of the requirements will vary based on location of the interconnection (isolated load and available fault current).

Certain major component, relaying, telemetry, and operational requirements must be met to provide compatibility between the Project equipment and the Utility electric system, and to assure that the safety and reliability of the electric system is not degraded by the interconnection.

Upgraded revenue metering may be required.

### ***Major Component Design Requirements***

The data requested in Appendix B or C, for all major equipment and relaying proposed by the Project Developer, must be submitted as part of the initial application for review and approval by the Utility. The Utility may request additional data be submitted as necessary during the study phase to clarify the operation of the Project.

Once installed, the interconnection equipment must be reviewed and approved by the Utility prior to being connected to the Utility electric system and before Parallel Operation is allowed.

### **Data**

The data that the Utility requires to evaluate the proposed interconnection is documented on “fill in the blank” checklists by generator type in Appendices B and C.

A site plan, electrical one-lines, and interconnection protection system details of the Project are required as part of the application data. The generator manufacturer data package should also be supplied.

### **Isolating Transformer(s)**

If an isolating transformer is required, the transformer must comply with the current ANSI Standard C57.12.

The transformer must have voltage taps on the high and/or low voltage windings sufficient to assure satisfactory generator operation over the range of voltage variation expected on the Utility electric system. The Project Developer also needs to assure sufficient voltage regulation at its Project to maintain an acceptable voltage level for its equipment during such periods when its Project is off-line. This may involve the provision of voltage regulation or a separate transformer between the Utility and the Project station power bus.

The type of generation and electrical location of the interconnection will determine the isolating transformer connections. Allowable connections are detailed under the specific generator type. Note: Some Utilities do not allow an isolation transformer to be connected to a grounded Utility system with an ungrounded secondary (Utility side) winding configuration, regardless of the Project type. Therefore, the Project Developer is encouraged to consult with the Utility prior to submitting an application.

The proper selection and specification of transformer impedance is important relative to enabling the proposed Project to meet the Utility’s reactive power requirements (see “Reactive Power Control”).

### **Isolation Device**

An isolation device is required and should be placed at the Point of Common Coupling (PCC). It can be a circuit breaker, circuit switcher, pole top switch, load-break disconnect, etc., depending on the electrical system configuration. The following are required of the isolation device:

# TECHNICAL REQUIREMENTS

- Must be approved for use on the Utility system.
- Must comply with current relevant ANSI and/or IEEE Standards.
- Must have load break capability, unless used in series with a three-phase interrupting device.
- Must be rated for the application.
- If used as part of a protective relaying scheme, it must have adequate interrupting capability. The Utility will provide maximum short circuit currents and X/R ratios available at the PCC upon request.
- Must be operable and accessible by the Utility at all times (24 hours a day, 7 days a week).
- The Utility will determine if the isolation device will be used as a protective tagging point. If the determination is so made, the device must have visible open break provisions for padlocking in the open position, and it must be gang operated. If the device has automatic operation, the controls must be located remote from the device.

## **Interconnection Lines**

The physically closest available system voltage, as well as equipment and operational constraints influence the chosen point of interconnection. The Utility has the ultimate authority to determine the acceptability of a particular PCC.

Any new line construction to connect the Project to the Utility's electric system will be undertaken by the Utility at the Project Developer's expense. The new lines will terminate on a termination structure provided by the Project Developer.

## **Termination Structure**

The Project Developer is responsible for ensuring that structural material strengths are adequate for all requirements, incorporating appropriate safety factors. Upon written request, the Utility will provide line tension information for maximum line dead-end tensions under heavy icing conditions. The structure must be designed for this maximum line tension along with an adequate margin of safety.

Substation electrical clearances shall comply with requirements of the National Electrical Safety Code and Michigan Public Service Commission Standard 16-79.

The installation of disconnect switches, bus support insulators, and other equipment shall comply with accepted industry practices.

Surge arresters shall be selected to coordinate with the BIL rating of major equipment components and shall comply with recommendations set forth in the current ANSI Standard C62.2.

## ***Relaying Design Requirements***

The interconnection relaying design requirements are intended to assure protection of the Utility electric system. Any additional relaying which may be necessary to protect equipment at the Project is solely the responsibility of the Project Developer to determine, design, and apply.

The relaying requirements will vary with the capacity rating of the Project, the type of generation being used, and the mode of operation (Flow-back or Non-Flow-back).

All relaying proposed by the Project Developer to satisfy these requirements must be submitted for review and approved by the Utility.

# TECHNICAL REQUIREMENTS

## **Protective Relaying General Considerations**

Utility grade relays are required. See “Approved Relay Types” in the Generator Interconnection Supplement.

All relays must be equipped with targets or other visible indicators to indicate that the relay has operated.

If the protective system uses AC power as the control voltage, it must be designed to disconnect the generation from the Utility electric system if the AC control power is lost.

The relay system must be designed such that the generator is prevented from energizing the Utility electric system if that system is de-energized.

## **Momentary Paralleling**

For situations where the Project will only be operated in parallel with the Utility electric system for a short duration (100 milliseconds or less), as in a make-before-break automatic transfer scheme, no additional relaying is required. Such momentary paralleling requires a modern integrated Automatic Transfer Switch (ATS) system, which is incapable of paralleling the Project with the Utility electric system. The ATS must be tested and verified for proper operation at least every 2 years. The Utility may be present during this testing.

## **Instrument Transformer Requirements**

All relaying must be connected into instrument transformers.

All current connections shall be connected into current transformers (CTs). All CTs shall be rated to provide no more than 5 amperes secondary current for all normal load conditions, and must be designed for relaying use, with an “accuracy class” of at least C50. Current transformers with an accuracy class designation such as T50 are NOT acceptable. For three-phase systems, all three phases must be equipped with CTs.

All potential connections must be connected into voltage transformers (VTs). For single-phase connections, the VTs shall be provided such that the secondary voltage does not exceed 120 volts for normal operations. For three-phase connections, the VTs shall be provided such that the line-to-line voltage does not exceed 120 volts for normal operation, and both the primary and secondary of the VTs shall be connected for grounded-wye connections.

## **Direct Transfer Trip (DTT)**

Direct Transfer Trip is generally not required for Induction or Inverter-Type generators. Direct Transfer Trip is generally not required for Synchronous Projects that will operate in the Non-Flow-back Mode since a more economic reverse power relay scheme can usually meet the requirements. For Synchronous Flow-back Projects the need for DTT is determined based on the location of the PCC. The Utility requires DTT when the total generation within a protective zone is greater than 33% of the minimum Utility load that could be isolated along with the generation. This prevents sustained isolated operation of the generation for conditions where generator protective relaying may not otherwise operate (see “Isolated Operation” in the Generator Interconnection Supplement).

Direct transfer trip adds to the cost and complexity of an interconnection. A DTT transmitter is required for each Utility protective device whose operation could result in sustained isolated operation of the generator. An associated DTT receiver at the Project is required for each DTT transmitter. A phone Data Circuit is required between each transmitter and receiver. Telemetry is required to monitor the status of the DTT communication, even if telemetry would not otherwise have been required.

At the Project Developer’s expense, the Utility will provide the receiver(s) that the Project Developer must install, and the Utility will install the transmitter(s) at the appropriate Utility protective devices.

# TECHNICAL REQUIREMENTS

## **Reverse Power Relaying for Non-Flow-back**

If metering for "Flow-back" Mode is not present, reverse power protection must be provided. The reverse power relaying will detect power flow from the Project into the Utility system, and operation of the reverse power relaying will separate the Project from the Utility system.

## **Automatic Reclosing**

The Utility employs automatic multiple-shot reclosing on most of the Utility's circuit breakers and circuit reclosers to increase the reliability of service to its customers. Automatic single-phase overhead reclosers are regularly installed on distribution circuits to isolate faulted segments of these circuits.

The Project Developer is advised to consider the effects of Automatic Reclosing (both single-phase and three-phase) to assure that the Project's internal equipment will not be damaged. In addition to the risk of damage to the Project, an out-of-phase reclosing operation may also present a hazard to the Utility's electric system equipment since this equipment may not be rated or built to withstand this type of reclosing.

To prevent out-of-phase reclosing, circuit breakers can be modified with voltage check relays. These relays block reclosing until the parallel generation is separated and the line is "de-energized." Hydraulic single-phase overhead reclosers cannot be modified with voltage check relays; therefore, these devices will have to be either replaced with three-phase overhead reclosers, which can be voltage controlled, or relocated beyond the Project location - depending upon the sectionalizing and protection requirements of the distribution circuit.

If the Project can be connected to more than one circuit, these revisions may be required on the alternate circuit(s) as well.

The Utility will determine relaying and control equipment that needs to be installed to protect its own equipment from out-of-phase reclosing. Installation of this protection will be undertaken by the Utility at the Project Developer's expense.

## **Single-Phase Sectionalizing**

The Utility also installs single-phase fuses and/or reclosers on its distribution circuits to increase the reliability of service to its customers. Three-phase generator installations may require replacement of fuses and/or single-phase reclosers with three-phase circuit breakers or circuit reclosers at the Project Developer's expense.

# TECHNICAL REQUIREMENTS

## Synchronous Projects

Under/overfrequency relaying and under/overvoltage relaying are required. Each generator must also be equipped with voltage-controlled overcurrent relays to detect faults on the utility system. The under/overvoltage relaying must be either a three-phase relay or three single-phase relays, and three-phase voltage controlled overcurrent relaying must be provided. In order to minimize damage to both the generator system equipment and to utility system equipment for loss-of-synchronism (also called out-of-step), and to minimize disruptions to other utility customers in the area, out-of-step relaying may also be required. The Utility has evaluated and approved a relay for this purpose, which would usually be installed at the same location as the metering, and would isolate the generation from the Utility system.

If the Project is connected to an ungrounded distribution system, the secondary winding (Utility side) of the isolation transformer must be connected delta.

If the Project is connected to a grounded distribution system, the developer has a choice of the following transformer connections:

1. The isolation transformer may be connected for a delta secondary (Utility side) connection with any primary (Project side) connection, or
2. The isolation transformer may be connected for an ungrounded-wye secondary (Utility side) connection with a delta primary (Project side) connection, or
3. The isolation transformer may be connected for a grounded wye-grounded wye connection if the Project provides less than 20% of the total single line-to-ground fault current at the PCC.

If the Project is connected to a grounded distribution system via one of the isolation transformer connections specified above, ground fault detection for Utility faults must be provided, and will consist of a (59N) ground overvoltage relay or (51N) overcurrent relay. The specific application of this relay will depend on the connection of the isolation transformer:

1. If a delta secondary/grounded-wye primary connection is used, a (59N) ground overvoltage relay will be connected into the secondary of a set of three-phase VTs, which will be connected grounded-wye primary, with the secondary connected delta with one corner of the delta left open. The (59N) relay will be connected across this open-corner.
2. If an ungrounded-wye secondary/delta primary connection is used, a (59N) ground overvoltage relay will be connected into the secondary of a single VT that will be connected from the ungrounded-wye neutral of the isolation transformer to ground.
3. If a grounded wye-grounded wye connection is used, a time overcurrent relay must be connected into a CT located on the Utility side isolation transformer neutral connection.

If the Project is connected to voltages above 20 kV, the isolation transformer connection will be determined by the Utility for the specific system location. The potential connection alternatives will include all alternatives listed above for application on a grounded distribution system, but will add a possible connection of grounded-wye (Utility side), delta (Project side). In the case of this additional isolation transformer connection, Utility system ground fault detection will take the form of a time overcurrent relay connected into a current transformer located in the Utility-side transformer neutral. This time overcurrent relay must have a very-inverse time characteristic.

For a sample One-Line Diagram of this type of facility including the various methods of (59N) application, see Appendix B.

# TECHNICAL REQUIREMENTS

## Induction Projects

Three-phase under/overvoltage relays and three-phase under/overfrequency relays must be provided. Utility-grade relays are required.

If the Project is connected to an ungrounded distribution system, the secondary winding (Utility side) of the isolation transformer must be connected delta.

If the Project is connected to a grounded distribution system, the Project Developer has a choice of the following transformer connections:

1. The isolation transformer may be connected for a delta secondary (Utility side) connection with any primary (Project side) connection, or
2. The isolation transformer may be connected for an ungrounded-wye secondary connection with a delta primary connection, or
3. The isolation transformer may be connected for a grounded wye-grounded wye connection.

If the Project is connected to a grounded distribution system via one of the isolation transformer connections specified above, ground fault detection for Utility faults must be provided. The specific application of this relay will depend on the connection of the isolation transformer:

1. If a delta secondary/grounded-wye primary connection is used, a (59N) ground overvoltage relay will be connected into the secondary of a set of three-phase VTs, which will be connected grounded-wye primary, with the secondary connected delta with one corner of the delta left open. The (59N) relay will be connected across this open-corner.
2. If an ungrounded-wye secondary/delta primary connection is used, a (59N) ground overvoltage relay will be connected into the secondary of a single VT that will be connected from the ungrounded-wye neutral of the isolation transformer to ground.
3. If a grounded wye-grounded wye connection is used, a time overcurrent relay must be connected into a CT located on the Utility side isolation transformer neutral connection.

Protection must be provided for internal faults in the isolating transformer. In cases where it can be shown that self excitation of the induction generator cannot occur when isolated from the Utility, the Utility may waive the requirement that the Project Developer provide protection for Utility system ground faults.

For a sample One-Line Diagram of this type of facility, see Appendix B.

# TECHNICAL REQUIREMENTS

## Inverter-Type Projects

Under/overfrequency relaying and under/overvoltage relaying are required. The under/overvoltage relaying must be either a three-phase relay or three single-phase relays.

The isolation transformer (without generation on-line) must be incapable of producing ground fault current to the Utility system; any connection except delta primary (Project side), grounded-wye secondary (Utility side) is acceptable. The isolation transformer must be protected for internal faults; fuses are acceptable.

If the inverter has passed a certified anti-island test, the Utility may waive the requirement that the Project Developer provide protection for the Utility system ground faults.

For a sample One-Line Diagram of this type of facility, see Appendix C.

# TECHNICAL REQUIREMENTS

## **Relay Setting Criteria**

The relay settings as detailed in this section will apply in the vast majority of applications. The Utility will issue relay settings for each individual project that will address the settings for these protective functions. All voltages will be adjusted for the specific VT ratio, and all currents will be adjusted for the specific CT ratio.

### *Undervoltage Relays*

The undervoltage relays will normally be set to trip at 88% of the nominal primary voltage at the relay location, and must reset from a trip condition if the voltage increases to 90% of the nominal primary voltage at the relay location. In order to accommodate variations in this criteria, the trip point of the relays shall be adjustable over a range of 70% of the nominal voltage to 90% of the nominal voltage. The trip time shall not exceed 1.0 seconds at 90% of the relay setting.

### *Overvoltage Relays*

Two steps of overvoltage relaying are required. For the first overvoltage set point, the overvoltage relays will normally be set to trip at 107% of the nominal primary voltage at the relay location, and must reset from a trip condition if the voltage decreases to 105% of the nominal primary voltage at the relay location. In order to accommodate variations in this criteria, the trip point of the relays shall be adjustable over a range of 105% of the nominal voltage to 120% of the nominal voltage. The trip time shall not exceed 1.0 seconds at 110% of the relay setting.

For the second overvoltage set point, the overvoltage relays will normally be set to trip at 120% of the nominal primary voltage at the relay location, and must reset from a trip condition if the voltage decreases to 118% of the nominal primary voltage at the relay location. In order to accommodate variations in this criteria, the trip point of the relays shall be adjustable over a range of 115% of the nominal voltage to 140% of the nominal voltage. The trip time shall be instantaneous (relay operating time not to exceed 0.02 seconds at 110% of the trip setting).

### *Underfrequency Relays*

The Underfrequency relay will normally be set for a trip point of 58.5 Hz, and must trip within 0.2 seconds. Relays with an inverse time characteristic (where the trip time changes with respect to the applied frequency) are not acceptable. These relays must respond reliably for applied source voltages as low as 70% of the nominal voltage.

### *Overfrequency Relays*

The overfrequency relay will normally be set for a trip point of 60.5 Hz, and must trip within 0.2 seconds. Relays with an inverse time characteristic are not acceptable. These relays must respond reliably for applied source voltages as low as 70% of the nominal voltage.

### *51V Relays – Voltage Controlled Overcurrent Relays*

For synchronous generator applications, the (51V) relays must be set to detect any phase faults that may occur between the generator and the nearest three-phase fault clearing device on the Utility system. Since these faults may take up to 1-second to detect and isolate, the appropriate saturated direct-axis reactance of the generator will be used depending on its time constants. The settings of this device will consider the relay manufacturer's recommended practice for the type of generator and prime mover (mechanical energy source), and will be determined by the Utility for the specific system application.

### *59N Relay – Ground Fault Detection*

This relay will be applied to detect ground faults on the Utility system when the Project is connected to a grounded Utility system via an ungrounded transformer winding. This relay will be set for a 10% shift in the apparent power system neutral. For an ungrounded wye transformer winding with a single 120 V secondary VT, the setting will usually be 12 Volts. For a delta transformer winding with broken delta 120 V secondary VTs, the setting will usually be 20 Volts. The time delay will normally be 1 second.

### *51N Relay – Ground Fault Detection*

# TECHNICAL REQUIREMENTS

This relay will be applied to detect ground faults on the Utility system when the Project is connected to a grounded Utility system via a grounded-wye transformer winding, and will be connected into a CT in the transformer neutral connection. This relay will be set to detect faults on the directly connected Utility system, and the timing will be set to comply with Utility practice for overcurrent relay coordination. The CT ratio and specific relay setting will be determined via a fault study performed by the Utility.

## *32 Relay – Reverse Power*

The reverse power relay must be selected such that it can detect a power flow into the Utility system of a small fraction of the overall generator capacity. The relay will normally be set near its minimum (most sensitive) setting, and will trip after a 1 second time delay. The delay will avoid unnecessary tripping for momentary conditions.

## **Maintenance and Testing**

The Utility reserves the right to test the relaying and control equipment that involves protection of the Utility electric system whenever the Utility determines a reasonable need for such testing exists.

The Project Developer is solely responsible for conducting proper periodic maintenance on the generating equipment and its associated control, protective equipment, interrupting devices, and main Isolation Device, per manufacturer recommendations.

The Project Developer is responsible for the periodic scheduled maintenance on those relays, interrupting devices, control schemes, and batteries that involve the protection of the Utility electric system. A periodic maintenance program is to be established to test these relays at least every 2 years. This maintenance testing must be witnessed by the Utility.

Each routine maintenance check of the relaying equipment shall include both an exact calibration check and an actual trip of the circuit breaker or contactor from the device being tested. For each test, a report shall be submitted to the Utility indicating the results of the tests made and the "as found" and "as left" relay calibration values. Visually setting, without verification, a calibration dial or tap is not considered an adequate relay calibration check.

The Project Developer is responsible for maintaining written reports for the above tests for a period of four years. These written reports shall be made available to the Utility upon request.

## **Installation and Design Approval**

The Project Developer must provide the Utility with 10 business days advance written notice of when the Project will be ready for inspection, testing, and approval.

The Utility may review the design drawings, for approval, after the Interconnection Study has been completed. The design drawings must be submitted by the Project Developer in accordance with "Engineering Design Drawing Requirements" (see Generator Interconnection Supplement). If reviewed, the Utility shall either approve the Project Developer's design drawings as submitted or return them to the Project Developer with a clear statement as to why they were not approved. Where appropriate, the Utility will indicate required changes on the engineering drawings.

In the event that revisions are necessary to the Project Developer's submitted design drawings and the Project Developer submits revised design drawings to the Utility, then the Utility shall either approve, in writing, the Project Developer's revised design drawings as resubmitted, or return them to the Project Developer with a clear statement as to why they were not approved. Where appropriate, the Utility will indicate required changes on the engineering drawings.

The Utility will retain one copy of the approved design drawings.

In the event that the Utility exercises its option to Acceptance Test the proposed interconnection relays that protect the Utility electric system, then the Utility shall communicate the results of that testing to the Project Developer for both the relays and the necessary documentation on the relays.

# TECHNICAL REQUIREMENTS

Prior to final approval for Parallel Operation, the Utility's specified relay calibration settings shall be applied and a commissioning test must be performed on the Project relaying and control equipment that involves the protection of the Utility electric system. The commissioning test must be witnessed by the Utility and can be performed by the Utility at the Project Developer's request. Upon satisfactory completion of this test and final inspection, the Utility will provide written permission for Parallel Operation. If the results are unsatisfactory, the Utility will provide written communication of these results and required action to the Project Developer.

In the event the Project Developer proposes a revision to the Utility's approved relaying and control equipment used to protect the Utility electric system and submits a description and engineering design drawings of the proposed changes, the Utility shall either approve the Project Developer's amended design drawings or return them to the Project Developer with a clear statement as to why they were not approved. Where appropriate, the Utility will indicate required changes on the engineering drawings.

## ***Telemetry and Disturbance Monitoring Requirements***

Telemetry and disturbance monitoring is required in all cases for Projects that will operate in the Flow-back Mode and have the capability to supply aggregate generation of 750 kW or more to the Utility. For generation facilities that will operate in the Non-Flow-back Mode, the requirement for telemetry will be determined on a case-by-case basis as part of the Interconnection Study.

Telemetry enables the Utility to operate the electric system safely and reliably under both normal and emergency conditions. The Utility measures its internal load plus losses (generation) on a real time basis via an extensive telemetry system. This system sums all energy flowing into the Utility electric system from Projects interconnected to the system and from interconnections with other utilities. During system disturbances when portions of the electrical systems are out of service, it is essential to know if a generator is on line or off line to determine the proper action to correct the problem. Time saved during restoration activities translates to fewer outages and outages of shorter duration for the Utility's customers.

The Utility evaluates the performance of the overall protective system for all faults on the electric system. It is critical that sufficient monitoring of the protective system is in place to determine its response. It is preferable to deploy disturbance monitoring into all Projects, but it can be expensive to deploy. Therefore, disturbance monitoring is required only for installations that already require telemetry.

The Project Developer shall provide a suitable indoor location, approved by the Utility, for the Utility's owned, operated, and maintained Remote Terminal Unit (RTU). The location must be equipped with a 48 V or 125 V DC power supply. The Project Developer must provide the necessary phone and data circuits, and install a telephone backboard for connections to the Utility RTU and metering equipment. All phone circuits must be properly protected as detailed in IEEE Std. 487. See "Typical Meter and RTU Installation Where Telemetry is Required" in the Generator Interconnection Supplement.

When telemetry is required, the following values will be telemetered:

1. Real and reactive power flow at the PCC.
2. Voltage at the PCC.
3. The status (normal/fail) of protective relay Communication Channels. A status indication of "FAIL" indicates the Communication Channel used for relaying (i.e. transfer trip) is unable to perform its protective function.
4. The status (open/closed) of the main isolating breaker and each generating unit breaker (if the Project is composed of multiple units, a single logical (OR) status of the individual generator breaker states,

# TECHNICAL REQUIREMENTS

indicating all generator breakers are open or any one or more generator breakers are closed, is permissible). A closed status would be indicated if any individual generator is on line.

For disturbance monitoring, the RTU will be equipped with “sequence of events” recording.

The Project Developer shall provide, wired to a terminal block near the RTU panel, sufficient connections to separately monitor the following:

1. An output contact of an instantaneous relay to act as a ground fault detector for faults on the Utility electric system. This relay shall be connected into the same sensing source as the ground fault protective relay required by the Utility.
2. Each and every trip of an interconnection isolation device, which is initiated by any of the generator interconnection relaying schemes required by the Utility.
3. Each and every trip of an interconnection isolation device, which is initiated by any of the protective systems for the generator.
4. Each and every trip or opening of an interconnecting isolation device, which is initiated by any other manual or electrical means.
5. A contact indicating the position of the Project’s primary-side main breaker.
6. A contact indicating operation of the over/undervoltage relays.
7. A contact indicating operation of the under/overfrequency relay or the Utility’s ground fault relay.
8. A contact indicating operation of the Project provided transformer bank relaying.
9. A contact indicating operation of any of the (51V) relaying.
10. A contact indicating the position of the high-side fault-clearing device.
11. A contact indicating the position of the reverse power relay, if said relay is required by the Utility.
12. The following individual contacts from each individual Direct Transfer Trip receiver, required by the Utility:
  - i. Loss-of-guard (LOG) alarm
  - ii. Receive-trip relay (RTX).
  - iii. Lockout relay.

If any of the functions indicated in items 2-4, 6, 7, 9, or 11 are combined into a multi-functional device, either:

1. Each of those functions must be monitored independently on the RTU, or
2. Provisions acceptable to the Utility must be provided to interrogate the multi-functional device such that the operation of the individual functions may be evaluated separately.

Telemetry, when required, will be provided by the Utility at the Project Developer's expense. In addition to other telemetry costs, a one-time charge will be assessed to the Project Developer for equipment and software installed at the Utility's System Control Center to process the data signals.

# TECHNICAL REQUIREMENTS

## ***Miscellaneous Operational Requirements***

Miscellaneous requirements include synchronizing equipment for Parallel Operation, reactive requirements, standby power considerations, and system stability limitations.

### **Operating in Parallel**

The Project Developer will be solely responsible for the required synchronizing equipment and for properly synchronizing the Project with the Utility electric system.

Voltage fluctuation at the PCC during synchronizing shall be limited to  $\pm 5\%$ .

The Project Developer will notify the Utility prior to synchronizing to and prior to scheduled disconnection from the electric system.

These requirements are directly concerned with the actual operation of the Project with the Utility:

- The Project may not commence parallel operation until approval has been given by the Utility. The completed installation is subject to inspection by the Utility prior to approval. Preceding this inspection, all contractual agreements must be executed by the Project Developer.
- The Project must be designed to prevent the Project from energizing into a de-energized Utility line. The Project's circuit breaker or contactor must be blocked from closing in on a de-energized circuit.
- The Project shall discontinue parallel operation with a particular service and perform necessary switching when requested by the Utility for any of the following reasons:
  1. When public safety is being jeopardized.
  2. During voltage or loading problems, system emergencies, or when abnormal sectionalizing or circuit configuration occurs on the Utility system.
  3. During scheduled shutdowns of Utility equipment that are necessary to facilitate maintenance or repairs. Such scheduled shutdowns shall be coordinated with the Project.
  4. In the event there is demonstrated electrical interference (i.e. Voltage Flicker, Harmonic Distortion, etc.) to the Utility's customers, suspected to be caused by the Project, and such interference exceeds then current system standards, the Utility reserves the right, at the Utility's initial expense, to install special test equipment as may be required to perform a disturbance analysis and monitor the operation and control of the Project to evaluate the quality of power produced by the Project. In the event that no standards exist, then the applicable tariffs and rules governing electric service shall apply. If the Project is proven to be the source of the interference, and that interference exceeds the Utility's standards or the generally accepted industry standards, then it shall be the responsibility of the Project Developer to eliminate the interference problem and to reimburse the Utility for the costs of the disturbance analysis, excluding the cost of the meters or other special test equipment.
  5. When either the Project or its associated synchronizing and protective equipment is demonstrated by the Utility to be improperly maintained, so as to present a hazard to the Utility system or its customers.
  6. Whenever the Project is operating isolated with other Utility customers, for whatever reason.
  7. Whenever a loss of communication channel alarm is received from a location where a communication channel has been installed for the protection of the Utility system.

# TECHNICAL REQUIREMENTS

8. Whenever the Utility notifies the Project Developer in writing of a claimed non-safety related violation of the Interconnection Agreement and the Project Developer fails to remedy the claimed violation within ten working days of notification, unless within that time either the Project Developer files a complaint with the MPSC seeking resolution of the dispute or the Project Developer and Utility agree in writing to a different procedure.

If the Project has shown an unsatisfactory response to requests to separate the generation from the Utility system, the Utility reserves the right to disconnect the Project from parallel operation with the Utility electric system until all operational issues are satisfactorily resolved.

## **Reactive Power Control**

Synchronous generators that will operate in the Flow-back Mode must be dynamically capable of providing 0.90 power factor lagging (delivering reactive power to the Utility) and 0.95 power factor leading (absorbing reactive power from the Utility) at the Point of Receipt. The Point of Receipt is the location where output of the Project is virtually metered.

Induction and Inverter-Type generators that will operate in the Flow-Back Mode must provide for their own reactive needs (steady state unity power factor at the Point of Receipt). To obtain unity power factor, the Induction or Inverter-Type Project can:

1. Install a switchable VAR supply source to maintain unity power factor at the Point of Receipt; or
2. Provide the Utility with funds to install a VAR supply source equivalent to that required for the Project to attain unity power factor at the Point of Receipt at full output.

There are no interconnection reactive power capability requirements for Synchronous, Induction, and Inverter-Type Projects that will operate in the Non-Flow-Back Mode. The Utility's existing rate schedules, incorporated herein by reference, contain power factor adjustments based on the power factor of the metered load at these facilities.

## **Standby Power**

Standby power will be provided under the terms of an approved rate set forth in the Utility's Standard Rules and Regulations. The Project Developer should be aware that to qualify for Standby Rates, a separate meter must be installed at the generator.

If outside of the Utility's franchise area, it will be the Project Developer's responsibility to arrange contractually and technically for the supply of its facility's standby, maintenance, and any supplemental power needs.

## **System Stability and Site Limitations**

The Stiffness Ratio is the combined three-phase short circuit capability of the Project and the Utility divided by the short circuit capability of the Project measured at the PCC. A stability study may be required for Projects with a Stiffness Ratio of less than 40. Five times the generator rated kVA will be used as a proxy for short circuit current contribution for induction generators. For synchronous Projects, with a Stiffness Ratio of less than 40, the Utility requires special generator trip schemes or loss of synchronism (out-of-step) relay protection. If the apparent voltage flicker from a loss-of-synchronism condition exceeds 5%, an out-of-step relay will be required. This type of protection is typically applied at the PCC and trips the entire Project off-line, if instability is detected, to protect the Utility electric system and its customers. If the Project Developer chooses not to provide for mitigation of unacceptable voltage flicker (above five percent), the Utility may disallow the interconnection of the Project or require a new dedicated interconnection at the Project Developer's expense.

A stability study may be required for induction Projects and wind turbine facilities to determine the impacts of sudden variation in real or reactive power output of the generators. The above Stiffness Ratio criteria

# TECHNICAL REQUIREMENTS

will be applied to determine if a stability study is required, with a proxy for the generator short circuit current calculated from five times the generator rated MVA.

The Project Developer is responsible for evaluating the consequences of unstable generator operation or voltage transients on the Project equipment and determining, designing, and applying any relaying which may be necessary to protect that equipment. This type of protection is typically applied on individual generators to protect the Project facilities.

The Utility will determine if operation of the Project will create objectionable voltage flicker and/or disturbances to other Utility customers and develop any required mitigation measures at the Project Developer's expense.

## ***Revenue Metering Requirements***

The Utility will own, operate, and maintain the billing metering equipment at the Project Developer's expense. The billing metering will meter both real and reactive interconnection flows between the Project and the Utility electric system. Where applicable, separate metering of station power may be required to accurately meter the Project load when the generator is off-line.

Special billing metering will be required for Projects operating in the Flow-back Mode. If telemetering is required, the billing metering will be included as part of the telemetering installation. The Project Developer will be required to provide, at no cost to the Utility, a dedicated dial-up voice-grade circuit (POTS) line, to allow remote access to the billing meter by the Utility. This circuit shall be terminated within ten feet of the meter involved.

The Project Developer shall provide a suitable indoor location, approved by the Utility, for the Utility's owned, operated, and maintained billing metering.

The Project Developer shall provide authorized employees and agents of the Utility access to the premises at all times to install, turn on, disconnect, inspect, test, read, repair, or remove the metering equipment. The Project Developer may, at its option, have a representative witness this work.

The metering installations for Flow-back operation shall be constructed in accordance with the practices, which normally apply to the construction of metering installations for commercial, industrial, or other customers with demand recording equipment.

The Utility shall supply to the Project Developer all required metering equipment and the standard detailed specifications and requirements relating to the location, construction, and access of the metering installation and will provide consultation pertaining to the meter installation as required. The Utility will endeavor to coordinate the delivery of these materials with the Project Developer's installation schedule during normal scheduled business hours.

The Project Developer shall provide a mounting surface for the meters, recorders, connection cabinets, a housing for the instrument transformers, a conduit for the conductors between the instrument transformer secondary windings and the meter connection cabinets, and a conduit for the communication links, if required. All of this equipment must meet the Utility's specifications and requirements.

The responsibility for the installation of the equipment is shared between the Utility and the Project Developer, with the Project Developer generally installing all of the equipment on its side of the Point of Interconnection, including instrument transformers, cabinets, conduits, and mounting surfaces. The Utility, or its agents, shall install the meters, recorders, and communication links. The Utility will endeavor to coordinate the installation of these items with the Project Developer's schedule.

# TECHNICAL REQUIREMENTS

## ***Communication Circuits***

The Project Developer is responsible for ordering and acquiring the telephone circuit required for the Project Interconnection. The Project Developer will assume all installation, operating, and maintenance costs associated with the telephone circuits, including the monthly charges for the telephone lines and any rental equipment required by the local telephone provider. However, at the Utility's discretion, the Utility may select an alternative communication method, such as wireless communications. Regardless of the method, the Project Developer will be responsible for all costs associated with the material and installation, whereas the Utility will be responsible to define the specific communication requirements.

The Utility will cooperate and provide Utility information necessary for proper installation of the telephone circuits upon written request.

All telephone circuits (both voice and data) must be analog circuits.

A dedicated dial-up voice-grade circuit (POTS line) is required for access to the billing meter by the Utility. When DTT is required, a modular RJ-11 jack must also be installed within six feet of the billing metering equipment, to allow the Utility to use this circuit for voice communication with personnel performing master station checkout of the RTU. This dial-up voice-grade circuit shall be a local telephone company provided business measured line without dial-in or dial-out call restrictions.

If DTT is required, a separate dedicated 4-wire, Class A, Data Circuit must be installed and protected as specified by the local telephone Utility for each DTT receiver and for the RTU. The circuit must be installed in rigid metallic conduit from the RTU and each DTT receiver to the point of connection to the telephone Utility equipment. Wall space must be provided for adjacent mounting next to the telephone board, of the billing metering panel and a telemetry enclosure. The billing metering panel is typically 60 inches high by 48 inches wide and the telemetry enclosure is typically 24 inches high by 24 inches wide. A clear space of 4.5 feet in front of this equipment is required to permit maintenance and testing. A review of each installation shall be made to determine the location and space requirements most agreeable to the Utility and the Project Developer.



**APPENDIX A**

**INTERCONNECTION APPLICATION**



**GENERATOR INTERCONNECTION APPLICATION**

AGGREGATE GENERATOR OUTPUT OF 750 kW OR MORE, BUT LESS THAN 2 MW

- 1. The undersigned Project Developer submits this Generator Interconnection Application and appropriate filing fee to interconnect a new Project to the Utility Electric System or to increase the capacity of an existing Project interconnected to the Utility Electric System.
- 2. A Project Developer requesting interconnection or an increase in the capacity of an existing generating facility to the Utility Electric System must provide the following information:
  - a. Completed Interconnection Application Data sheet appropriate for the capacity rating and type of generating unit(s), as found in the Utility’s Generator Interconnection Requirements (Interconnection Application Data sheet, found in Appendix B or C, must be attached to this Interconnection Application).
  - b. Description of the equipment configuration and proposed interconnection one-line diagram (one-line diagram must be attached to this Interconnection Application).

c. Project Developer (Single Point of Contact):

Name: \_\_\_\_\_

Address: \_\_\_\_\_

\_\_\_\_\_

Phone Number: \_\_\_\_\_

Fax Number: \_\_\_\_\_

Project Site Address: \_\_\_\_\_

- 3. This Generator Interconnection Application shall be directed to the Utility representative as indicated below:

Great Lakes Energy  
 1323 Boyne Avenue  
 P.O. Box 70  
 Boyne City, MI 49712  
 Attn: System Engineer

- 4. I, the undersigned and authorized representative of the Project Developer, submit this Generator Interconnection Application and required technical data for the Utility’s review. I understand that upon acceptance, the Utility shall subsequently provide an Interconnection Study Agreement. The Interconnection Study Agreement will include the Scope of the Interconnection Study. I also understand that I shall be required to furnish certain required technical data as requested by the Utility in support of this study and reimburse the Utility for its study expenses.

Authorized Signature: \_\_\_\_\_

Printed Name: \_\_\_\_\_

Title: \_\_\_\_\_

Company Name: \_\_\_\_\_

Date: \_\_\_\_\_



**APPENDIX B**

**SYNCHRONOUS AND INDUCTION  
GENERATORS  
AGGREGATE GENERATION OF 750 kW OR  
MORE, BUT LESS THAN 2 MW**

**REQUIRED DATA**





**ONE-LINE REPRESENTATION  
TYPICAL ISOLATION AND FAULT PROTECTION FOR INDUCTION GENERATOR  
INSTALLATIONS EQUAL TO OR LARGER THAN 750KW BUT LESS THAN 2000KW**

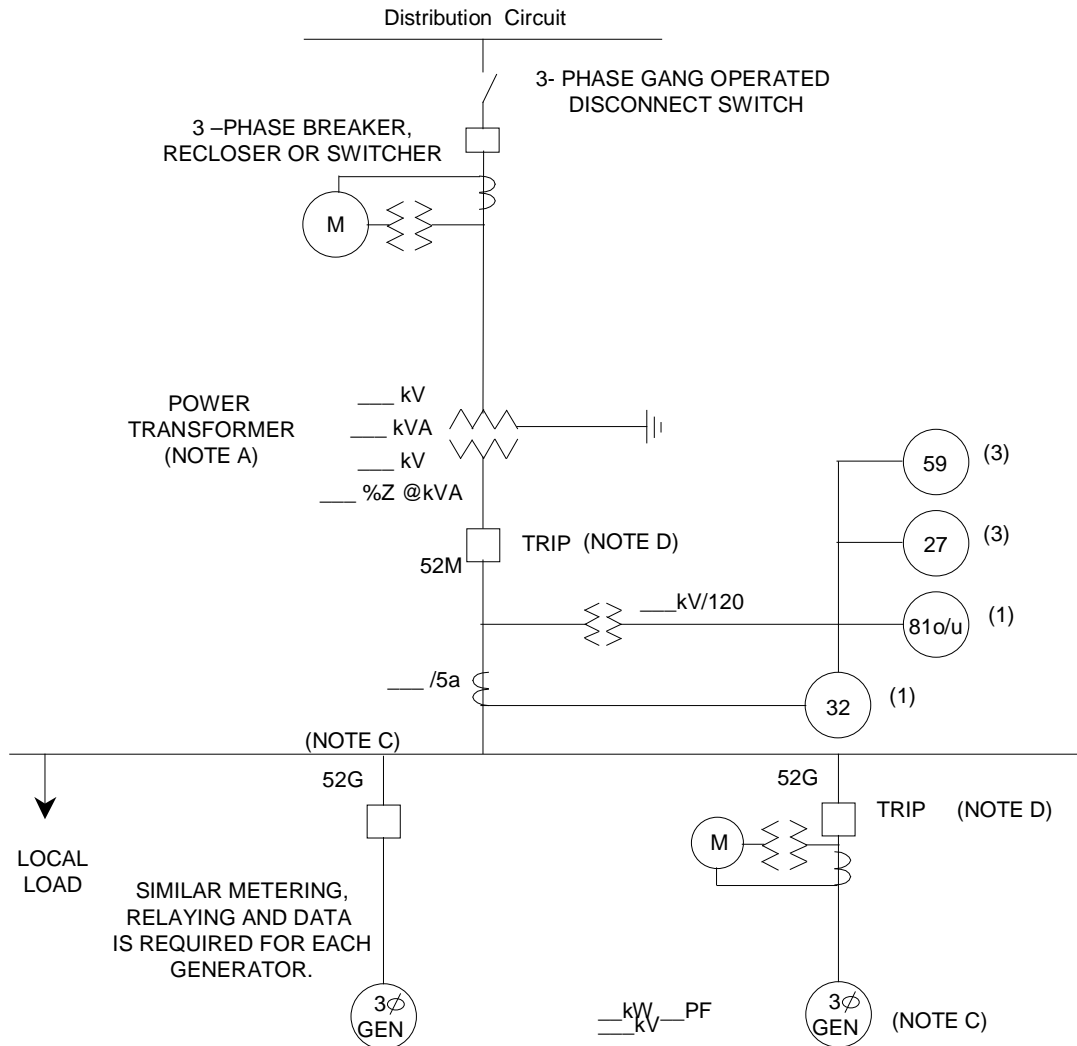

**LEGEND**

- 59 --- Overtoltage
- 27 -- Undervoltage
- 81o/u- Over/Underfrequency
- 32 - Reverse Power (not required for sellback)

**NOTES**

- A) See technical requirements for permissible connection configurations. Transformer connection and secondary grounding to be approved by utility.
- B) A wye connection is shown. A delta connection on the utility side is typically required for connection to an ungrounded utility system. VTs for 59, 27, 81o/u and 32 are shown on generator side of the power transformer. VT location is typically located electrically at the revenue metering location. IEEE std 1547 requirements for voltage and frequency must be met at the PCC. IEEE std. 1547 permits the voltage transformers to be connected at the point of generator connection in certain cases.
- C) Main breaker protection, generator protection and synchronizing equipment are not shown.
- D) Trip of either breaker is acceptable, depending upon whether the project developer wants to serve its own isolated load after loss of utility service.

**SYNCHRONOUS OR INDUCTION GENERATORS - AGGREGATE  $\geq$  750 kW,  
BUT  $<$  2 MW  
INTERCONNECTION APPLICATION DATA FOR: \_\_\_\_\_  
PROVIDED BY: \_\_\_\_\_ DATE: \_\_\_\_\_**

Instructions: Attach data sheets as required. Indicate in the tables below the page number of the attached data (manufacturer's data where appropriate) on which the requested information is provided. Provide one table for each unique transformer.

**General Information**

Item No	Data Description	Attached Page No
1	Flow-back or Non-Flow-back	
2	Project Type (Base load, peaking, intermediate)	
3	Site Plan	
4	Simple One-Line for Project and Project Load	
5	Detailed One-Line for Project	
6	Energization Date for Project Interconnection Facilities	
7	First Parallel Operation Date for Testing	
8	Project Commercial Operation Date	
9	Estimated Project Cost	

**Isolating Transformer(s) between Generator(s) and Utility: Transformer No \_\_\_\_\_**

Item No	Data Description	Attached Page No
1	Rated kV and connection (delta, wye, wye-gnd) of each winding	
2	kVA of each winding	
3	BIL of each winding	
4	Fixed taps available for each winding	
5	Positive/negative range for any LTC windings	
6	%Z Impedance on transformer self cooled rating	
7	Percent excitation current at rated kV	
8	Load Loss Watts at full load or X/R ratio	

The following information on these system components shall appear on the preliminary One-Line Diagram, including manufacturer make and model for the items listed below:

- Breakers - Rating, location and normal operating status (open or closed)
- Buses - Operating voltage
- Capacitors - Size of bank in kVAR
- Circuit Switchers - Rating, location and normal operating status (open or closed)
- Current Transformers - Overall ratio, connected ratio
- Fuses - normal operating status, rating (Amps), type
- Generators - Capacity rating (kVA), location, type, method of grounding
- Grounding Resistors - Size (ohms), current (Amps)
- Isolating transformers - Capacity rating (kVA), location, impedance, voltage ratings, primary and secondary connections and method of grounding
- Potential Transformers - Ratio, connection
- Reactors - Ohms/phase
- Relays - Types, quantity, IEEE device number, operator lines indicating the device initiated by the relays.
- Switches - Location and normal operating status (open or closed), type, rating
- Tagging Point - Location, identification

**SYNCHRONOUS GENERATORS - AGGREGATE  $\geq$  750 kW, BUT  $<$  2 MW  
INTERCONNECTION APPLICATION DATA FOR: \_\_\_\_\_**

**PROVIDED BY: \_\_\_\_\_ DATE: \_\_\_\_\_**

Instructions: Attach data sheets as required. Indicate in the table below the page number of the attached data (manufacturer's data where appropriate) on which the requested information is provided. Provide one table for each unique generator.

<b>Electric Generator(s) at the Project:</b>			<b>Generator No</b> _____
<b>Item No</b>	<b>Data Value</b>	<b>Data Description</b>	<b>Attached Page No</b>
1		Generator Type (synchronous or induction)	
2		Generator Nameplate Voltage	
3		Generator Nameplate Watts or Volt-Amperes	
4		Generator Nameplate Power Factor (pf)	
5		RPM	
6		Minimum and Maximum Acceptable Terminal Voltage	
7		Direct axis reactance (saturated)	
8		Direct axis reactance (unsaturated)	
9		Quadrature axis reactance (unsaturated)	
10		Direct axis transient reactance (saturated)	
11		Direct axis transient reactance (unsaturated)	
12		Quadrature axis transient reactance (unsaturated)	
13		Direct axis sub-transient reactance (saturated)	
14		Direct axis sub-transient reactance (unsaturated)	
15		Leakage Reactance	
16		Direct axis transient open circuit time constant	
17		Quadrature axis transient open circuit time constant	
18		Direct axis subtransient open circuit time constant	
19		Quadrature axis subtransient open circuit time constant	
20		Open Circuit saturation curve	
21		Reactive Capability Curve showing overexcited and underexcited limits (Reactive Information if non-synchronous)	
22		Excitation System Block Diagram with values for gains and time constants (Laplace transforms)	
23		Short Circuit Current contribution from generator at the Point of Common Coupling	
24		Rotating inertia of overall combination generator, prime mover, couplers and gear drives	
25		Station Power load when generator is off-line, Watts, pf	
26		Station Power load during start-up, Watts, pf	
27		Station Power load during operation, Watts, pf	
28		National Recognized Testing Laboratory Certification (if applicable)	
29		Written Commissioning Test Procedure	

**INDUCTION GENERATORS - AGGREGATE  $\geq$  750 kW, BUT  $<$  2 MW**

**INTERCONNECTION APPLICATION DATA FOR:** \_\_\_\_\_

**PROVIDED BY:** \_\_\_\_\_ **DATE:** \_\_\_\_\_

Instructions: Attach data sheets as required. Indicate in the table below the page number of the attached data (manufacturer's data where appropriate) on which the requested information is provided. Provide one table for each unique generator.

**Electric Generator(s) at the Project:** \_\_\_\_\_ **Generator No.** \_\_\_\_\_

Item No	Data Value	Data Description	Attached Page No
1		Generator Type (synchronous or induction)	
2		Generator Rated Voltage	
3		Generator Rated Volt-Amperes	
4		Generator Rated Power kW	
5		Number of Poles	
6		Synchronous Rotational Speed	
7		Rotation Speed at Rated Power	
8		Slip at Rated Power	
9		Minimum and Maximum Acceptable Terminal Voltage	
10		Motoring Power (kW)	
11		Neutral Grounding Resistor (If Applicable)	
12		$I_2^2t$ or K (Heating Time Constant)	
13		Rotor Resistance	
14		Stator Resistance	
15		Stator Reactance	
16		Rotor Reactance	
17		Magnetizing Reactance	
18		Short Circuit Reactance	
19		Exciting Current	
20		Temperature Rise	
21		Frame Size	
22		Design Letter	
23		Reactive Power Required in Vars (No Load)	
24		Reactive Power Required in Vars (Full Load)	
25		Short Circuit Current contribution from generator at the Point of Common Coupling	
26		Rotating inertia, H in Per Unit on kVA Base, of overall combination generator, prime mover, couplers and gear drives	
27		Station Power load when generator is off-line, Watts, pf	
28		Station Power load during start-up, Watts, pf	
29		Station Power load during operation, Watts, pf	
30		National Recognized Testing Laboratory Certification (if applicable)	
31		Written Commissioning Test Procedure	



## **APPENDIX C**

### **INVERTER-TYPE GENERATORS AGGREGATE GENERATION 750 kW OR MORE, BUT LESS THAN 2 MW**

#### **REQUIRED DATA**



**ONE-LINE REPRESENTATION**  
**TYPICAL ISOLATION AND FAULT PROTECTION FOR INVERTER TYPE GENERATOR**  
**INSTALLATIONS EQUAL TO OR LARGER THAN 750KW BUT LESS THAN 2000KW**

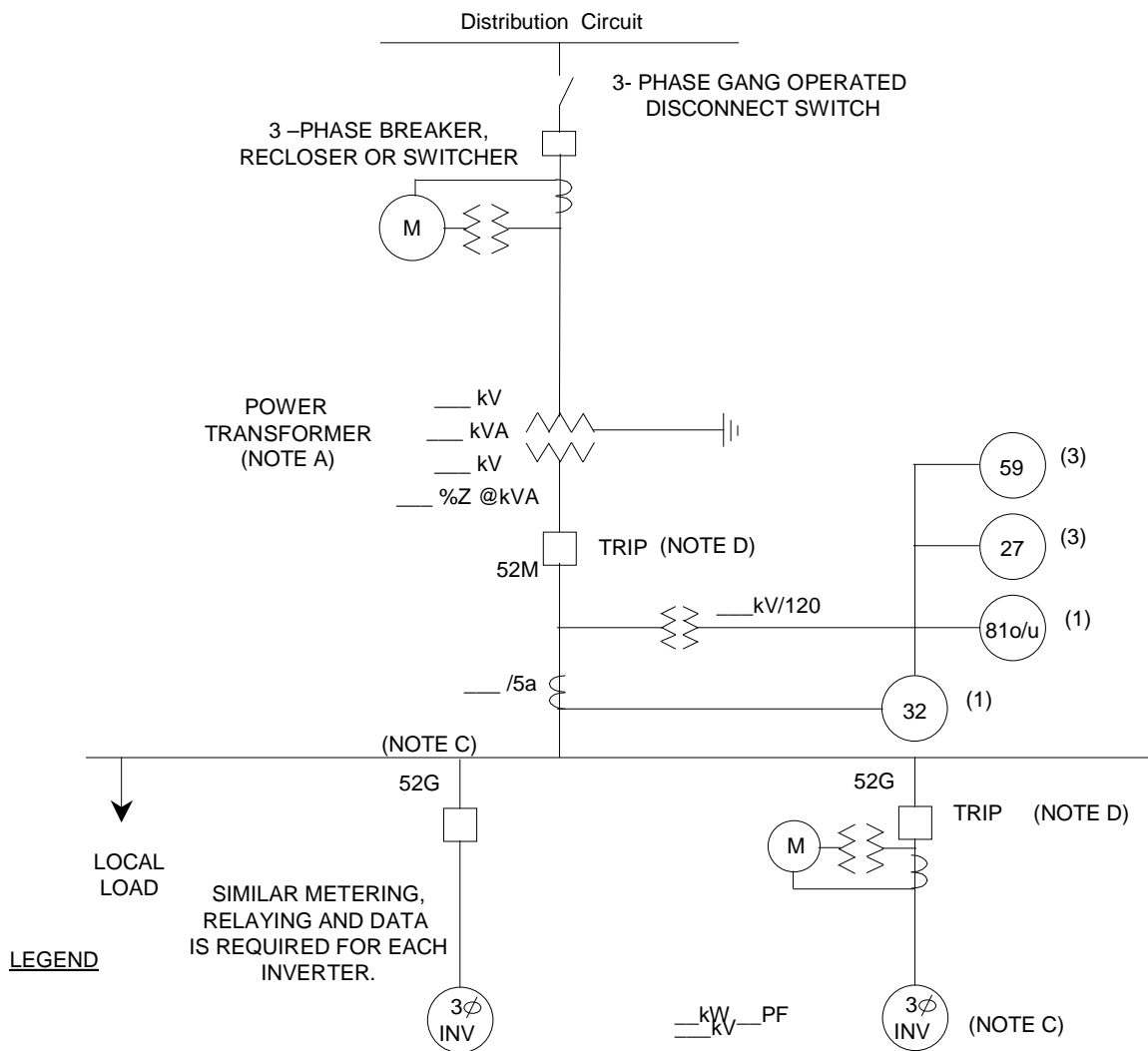

**LEGEND**

- 59 --- Overvoltage
- 27 -- Undervoltage
- 81o/u- Over/Underfrequency
- 32 - Reverse Power (not required for sellback)

**NOTES**

- A) See technical requirements for permissible connection configurations. Transformer connection and secondary grounding to be approved by utility.
- B) A wye connection is shown. A delta connection on the utility side is typically required for connection to an ungrounded utility system. VTs for 59, 27, 81o/u and 32 are shown on generator side of the power transformer. VT location is typically located electrically at the revenue metering location. IEEE Std 1547 requirements for voltage and frequency must be met at the PCC. IEEE Std. 1547 permits the voltage transformers to be connected at the point of generator connection in certain cases.
- C) Main breaker protection, generator protection and synchronizing equipment are not shown.
- D) Trip of either breaker is acceptable, depending upon whether the project developer wants to serve its own isolated load after loss of utility service.

**INVERTER-TYPE GENERATORS - AGGREGATE  $\geq$  750 kW, BUT  $<$  2 MW**  
**INTERCONNECTION APPLICATION DATA FOR: \_\_\_\_\_**  
**PROVIDED BY: \_\_\_\_\_ DATE: \_\_\_\_\_**

Instructions: Attach data sheets as required. Indicate in the tables below the page number of the attached data (manufacturer's data where appropriate) on which the requested information is provided. Provide one table for each unique transformer.

**General Information**

Item No	Data Description	Attached Page No
1	Flow-back or Non-Flow-back	
2	Project Type (Base load, peaking, intermediate, other)	
3	Site Plan	
4	Simple One-Line for Project and Project Load	
5	Detailed One-Line for Project	
6	Energization Date for Project Interconnection Facilities	
7	First Parallel Operation Date for Testing	
8	Project Commercial Operation Date	
9	Estimated Project Cost	

**Isolating Transformer(s) between Generator(s) and Utility: Transformer No \_\_\_\_\_**

Item No	Data Description	Attached Page No
1	Rated kV and connection (delta, wye, wye-gnd) of each winding	
2	kVA of each winding	
3	BIL of each winding	
4	Fixed taps available for each winding	
5	Positive/negative range for any LTC windings	
6	%Z Impedance on transformer self cooled rating	
7	Load Loss Watts at full load or X/R ratio	

The following information on these system components shall appear on the preliminary One-Line Diagram, including manufacturer make and model for the items listed below:

- Breakers - Rating, location and normal operating status (open or closed)
- Buses - Operating voltage
- Capacitors - Size of bank in kVAR
- Circuit Switchers - Rating, location and normal operating status (open or closed)
- Current Transformers - Overall ratio, connected ratio
- Fuses - normal operating status, rating (Amps), type
- Generators - Capacity rating (kVA), location, type, method of grounding
- Grounding Resistors - Size (ohms), current (Amps)
- Isolating transformers - Capacity rating (kVA), location, impedance, voltage ratings, primary and secondary connections and method of grounding
- Potential Transformers - Ratio, connection
- Reactors - Ohms/phase
- Relays - Types, quantity, IEEE device number, operator lines indicating the device initiated by the relays.
- Switches - Location and normal operating status (open or closed), type, rating
- Tagging Point - Location, identification

**INVERTER-TYPE GENERATORS - AGGREGATE  $\geq$  750 kW, BUT  $<$  2 MW**  
**INTERCONNECTION APPLICATION DATA FOR: \_\_\_\_\_**  
**PROVIDED BY: \_\_\_\_\_ DATE: \_\_\_\_\_**

Instructions: Attach data sheets as required. Indicate in the table below the page number of the attached data (manufacturer's data where appropriate) on which the requested information is provided. Provide one table for each unique generator.

<b>Electric Generator(s) at the Project:</b>		<b>Generator No _____</b>
<b>Item No</b>	<b>Data Description</b>	<b>Attached Page No</b>
1	Generator Type (Inverter)	
2	Generator Nameplate Voltage	
3	Generator Nameplate Watts or Volt-Amperes	
4	Generator Nameplate Power Factor (pf)	
5	Minimum and Maximum Acceptable Terminal Voltage	
6	Reactive Capability Curve showing overexcited and underexcited limits (Reactive Information if non-synchronous)	
7	Short Circuit Current contribution from generator at the Point of Common Coupling	
8	Station Power load when generator is off-line, Watts, pf	
9	Station Power load during start-up, Watts, pf	
10	Station Power load during operation, Watts, pf	



## **APPENDIX D**

# **INTERCONNECTION STUDY AGREEMENT**



# Great Lakes Energy

\_\_\_\_\_  
[Project]

## Interconnection Study Agreement for Generator Interconnection

With Aggregate Project Output of 750 kW or More, but Less than 2 MW

WHEREAS, proposals to construct or upgrade a Project which will be operated in parallel with and interconnected with the Great Lakes Energy (“Utility”) electric system must be reviewed by the Utility to determine how it will impact the Utility’s electric system.

WHEREAS, on \_\_\_\_\_ Utility received from \_\_\_\_\_ (“Project Developer”) a Generator Interconnection Application.

WHEREAS Utility has determined that an Interconnection Study is necessary to determine whether the Utility electric system can accommodate the requested interconnection.

NOW, THEREFORE, in consideration of the mutual covenants and agreements herein set forth, Utility and the Project Developer agree as follows:

1. Utility shall complete an Interconnection Study in accordance with Utility’s Generator Interconnection Requirements and this Agreement.
2. The Utility is permitted by the Michigan Public Service Commission to charge the Project Developer for an Interconnection Study. The charges shall not exceed the lesser of either of the following:
  - (a) 5% of the estimated total cost of the Project or
  - (b) \$10,000

The Utility shall not charge the Project Developer if the Project's aggregate export capacity is less than 15% of the line section peak load and the Project does not contribute more than 25% of the maximum short circuit current at the point of interconnection. The Project Developer will be billed for the cost of the Interconnection Study at the conclusion of the Interconnection Study.

3. The Project Developer is to return this executed Interconnection Study Agreement to the Utility as soon as possible. The interconnection process will not proceed until the fully executed Interconnection Study Agreement is received.
4. The Utility shall supply a copy of the completed Interconnection Study to the Project Developer.
5. Any notice or request made to or by either Party regarding this Agreement shall be made to the representative of the other Party, or its designated agent, as indicated below.

Utility

Project Developer

Name \_\_\_\_\_

\_\_\_\_\_

Company \_\_\_\_\_

\_\_\_\_\_

Address 1 \_\_\_\_\_

\_\_\_\_\_

Address 2 \_\_\_\_\_

\_\_\_\_\_

IN WITNESS WHEREOF, the Parties have caused this Interconnection Study Agreement to be executed by their respective authorized officials.

\_\_\_\_\_  
By:

\_\_\_\_\_  
By:

\_\_\_\_\_  
(Signature)

\_\_\_\_\_  
(Signature)

\_\_\_\_\_  
(Typewritten or Printed Name)

\_\_\_\_\_  
(Typewritten or Printed Name)

\_\_\_\_\_  
Title

\_\_\_\_\_  
Title

\_\_\_\_\_  
Date

\_\_\_\_\_  
Date

## **APPENDIX E**

### **INTERCONNECTION AND OPERATING AGREEMENT**

**Agreement Contract is available upon request.**

## **APPENDIX F**

### **CONTACT LIST**

**List available upon request.**